



City of NAPOLEON, OHIO

255 WEST RIVERVIEW AVENUE, P.O. BOX 151
NAPOLEON, OHIO 43545-0151
(419) 592-4010
FAX (419) 599-8393

Wednesday, July 3, 1996

F. E. D. Corporation
Dave Nagel, Project Manager
2510 West M-61
Gladwin, MI 48624

Mayor
Donald M. Stange

Re: Quick Lube Water Service

Dear Dave:

Members of Council
Michael J. DeWit, President
Sarah J. Peper
John E. Church
James Hershberger
Terri A. Williams
Travis B. Sheaffer
Dennis Fligor

This letter is in response to our recent conversations regarding the water service at the proposed Quick Lube which is opening in Napoleon. The estimate for the water tap is \$3,100. Please see the enclosed attachment for the cost breakdown.

City Manager
Marc S. Gerken, P.E.

Your firm will be responsible to install the pipe from the point of the 4" tap valve to the building. The City will be allowing your firm to make a 1" tap for the domestic water service off the 4" line at or near the right-of-way. You will need to set a curb stop, box and rod assembly at the right-of-way for the domestic service. The curb stop assembly must meet the City of Napoleon specifications which are on file in the Engineering Department.

Finance Director
Gregory J. Heath

The City of Napoleon will be requiring backflow prevention at this site. You will need to place a dual detector check assembly on the fire line and a reduced pressure device on the domestic service.

Law Director
David M. Grahn

The City will allow your firm to open cut Lagrange Street for the pipe placement. In doing this, you will be responsible to replace the street area back to its original condition. The pipe placement and restoration work must be scheduled with the Engineering Department for inspection. You will also be responsible for all signage, traffic control, road closings and contacting the local media of the time and date of the closing.

City Engineer
Adam C. Hoff, P.E.

Should you require further information on this matter, please feel free contact my office at (419) 599-1891.

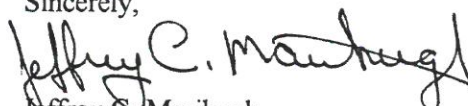
Sincerely,

Jeffrey C. Marihugh
Operations Superintendent

JCM:ka

cc: Adam Hoff, P.E., City Engineer
Charlie Heinze, Water Distribution Foreman
Sonny Helberg, Construction Inspector
Brent Damman, Building & Zoning Administrator

4" Tap for Pioneer Quick Lube

Material:

12" X 4" tap sleeve	\$273.19
4" tap valve	\$222.23
valve box	\$ 76.74
5/8" meter	\$ 72.00
5/8" copper setter	\$ 20.00
Stone - 15 ton	\$119.25
Concrete - 4 cu. yd.	\$280.00
Asphalt - 1.5 ton	\$ 45.00

Labor:

4" tap (sub contracted)	\$300.00
Backhoe with operator - 4 hr..	\$240.00
General Labor -2 men - 6 hr..	\$240.00
Labor for asphalt restoration - 3 hr..	\$180.00

Sub Total:	\$2,068.41
50% up charge	\$1,034.21

Total: \$3,102.62



City of NAPOLEON, OHIO

255 WEST RIVERVIEW AVENUE, P.O. BOX 151
NAPOLEON, OHIO 43545-0151
(419) 592-4010
FAX (419) 599-8393

May 6, 1996

Mayor
Donald M. Stange

Mr. Mike Ridley
FED Corporation
2510 West M-61
Gladwin, Michigan 48624

Members of Council
Michael J. DeWit, President
Sarah J. Peper
John E. Church
James Hershberger
Terri A. Williams
Travis B. Sheaffer
Dennis Fligor

Re: Pioneer Quick Lube
Plan Review

Dear Mr. Ridley:

Based upon review of the plans for the proposed development by
City personnel, we hereby approve the plans as submitted.

City Manager
Marc S. Gerken, P.E.

If you have any questions, please call me.

Finance Director
Gregory J. Heath

Yours truly,

Law Director
David M. Grahn

Adam C. Hoff, P.E.
City Engineer

City Engineer
Adam C. Hoff, P.E.

ACH:rd

cc: Brent Damman, Building/Zoning Administrator
Sonny Helberg, Construction Inspector

C:\AMIPRO\CITYENGR\LETTERS\RIDLYPNZ.SAM May 6, 1996 11:32 AM



City of NAPOLEON, OHIO

255 RIVERVIEW AVENUE, P.O. BOX 151
NAPOLEON, OHIO 43545-0151
(419) 592-4010

October 31, 1995

Mayor
Robert G. Heft

Mr. Mike Ridley
FED Corporation
2510 West M-61
Gladwin, Michigan 48626

Members of Council
John E. Church, President
Michael J. DeWit
James Hershberger
Sarah Peper
Terri A. Williams
Travis B. Sheaffer
Dennis Filgor

Re: Pioneer Quick Lube
1108 North Scott Street

City Manager
Marc S. Gerken

Dear Mr. Ridley:

Enclosed please find one (1) copy of the memorandum provided to me by the City of Napoleon Building Inspector/Zoning Administrator, Mr. Brent Damman. We request that these comments be addressed prior to the further review of the proposed facility.

Finance Director
Gregory J. Heath

If you should have any questions, please call us.

Law Director
David M. Grahn

Yours truly,

City Engineer
Adam C. Hoff, P.E.

Adam C. Hoff, P.E.
City Engineer

ACH:rd
Enclosure
cc: Mr. Brent Damman, Bldg./Zoning Administrator

MEMO

To: Adam C. Hoff, City Engineer
From: Brent N Damman, Building & Zoning Administrator *BND*
Date: Monday, October 30, 1995
Subject: Pioneer Quick Lube 1108 Scott Street

The following are changes and additions needed to the plans submitted on the above subject.

1. Dumpster screening required; show type and height proposed, also show thickness of concrete pad.
2. Change sanitary sewer size to 6", use ROMAC CB-6.66 UN tap saddle over cored hole in City main.
3. Show on - site directional traffic signage.
4. Reduce height of Pennzoil post sign to eighteen (18) feet or less from finished grade to top of sign.
5. Place elevations on final plans as indicated on the enclosed drawing.
6. Show storm tap three (3) feet west of curb drain along Lagrange Street as shown on the enclosed drawings.
7. Show proposed drainage for the area around the post sign.
8. Show the City's ten (10) foot permanent utility easement along Lagrange street.
9. Move drive off City utility easement.
10. Show sidewalk cross section detail indicating proposed finished dirt grade and slopes. Sidewalks shall be placed one (1) foot north of south easement line as indicated on the enclosed drawing.

11. The City will provide a one (1) inch and a two (2) inch water tap to the location shown on the enclosed drawing. The cost of the one (1) inch tap to be \$650.00 and the cost of the two (2) inch tap to be \$1425.00.
12. The contractor is responsible for making the sanitary sewer tap as well as the storm sewer tap, the City inspection fee for these taps is \$100.00
13. The fire line and potable water risers shall be configured so that the backflow device is downstream from the City water meter as shown on the enclosed City installation spec.

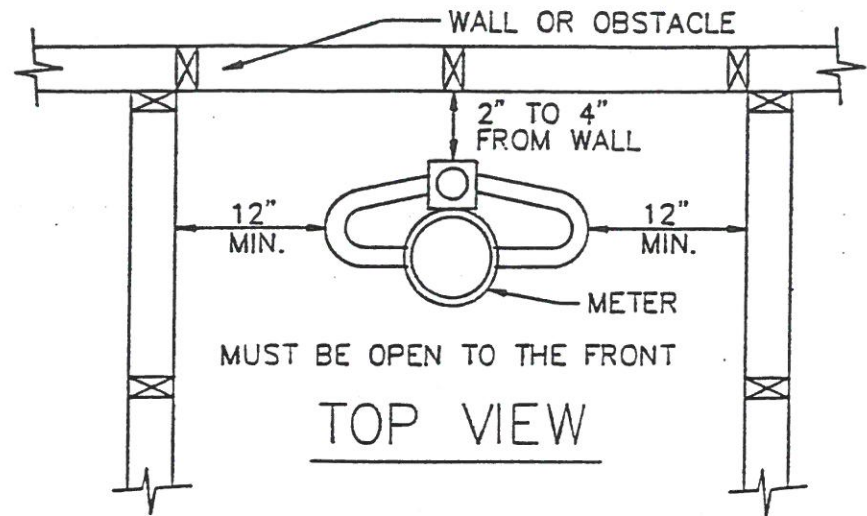

MUST BE OPEN TO THE FRONT

TOP VIEW

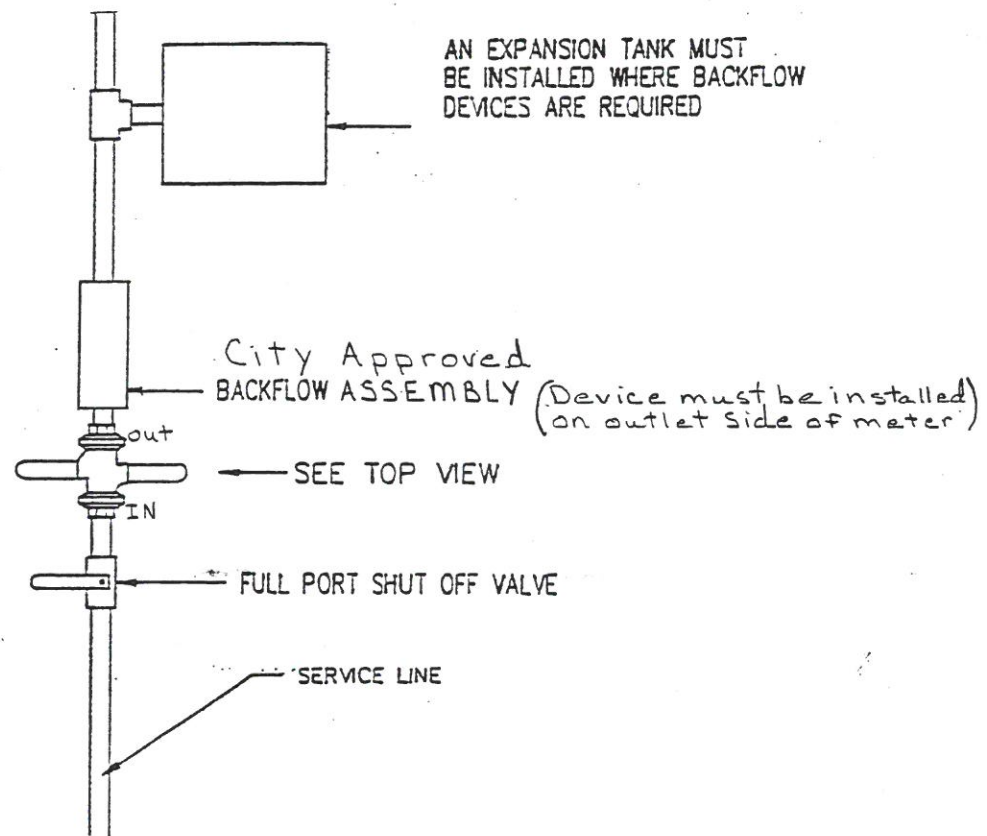

AN EXPANSION TANK MUST BE INSTALLED WHERE BACKFLOW DEVICES ARE REQUIRED

City Approved BACKFLOW ASSEMBLY (Device must be installed on outlet side of meter)

SEE TOP VIEW

FULL PORT SHUT OFF VALVE

SERVICE LINE

SIDE VIEW



CITY OF NAPOLEON, OHIO
ENGINEERING DEPT.
255 W. RIVERVIEW DR.
419-592-4010

TITLE: WATER METER INSTALLATION

SCALE: NONE
DATE: 5/88

FROM DWG. NO. SD\1-3-1.DWG
PLOT SCALE 1=10 04403901.DWG 11 MAY 93 ROF

METER

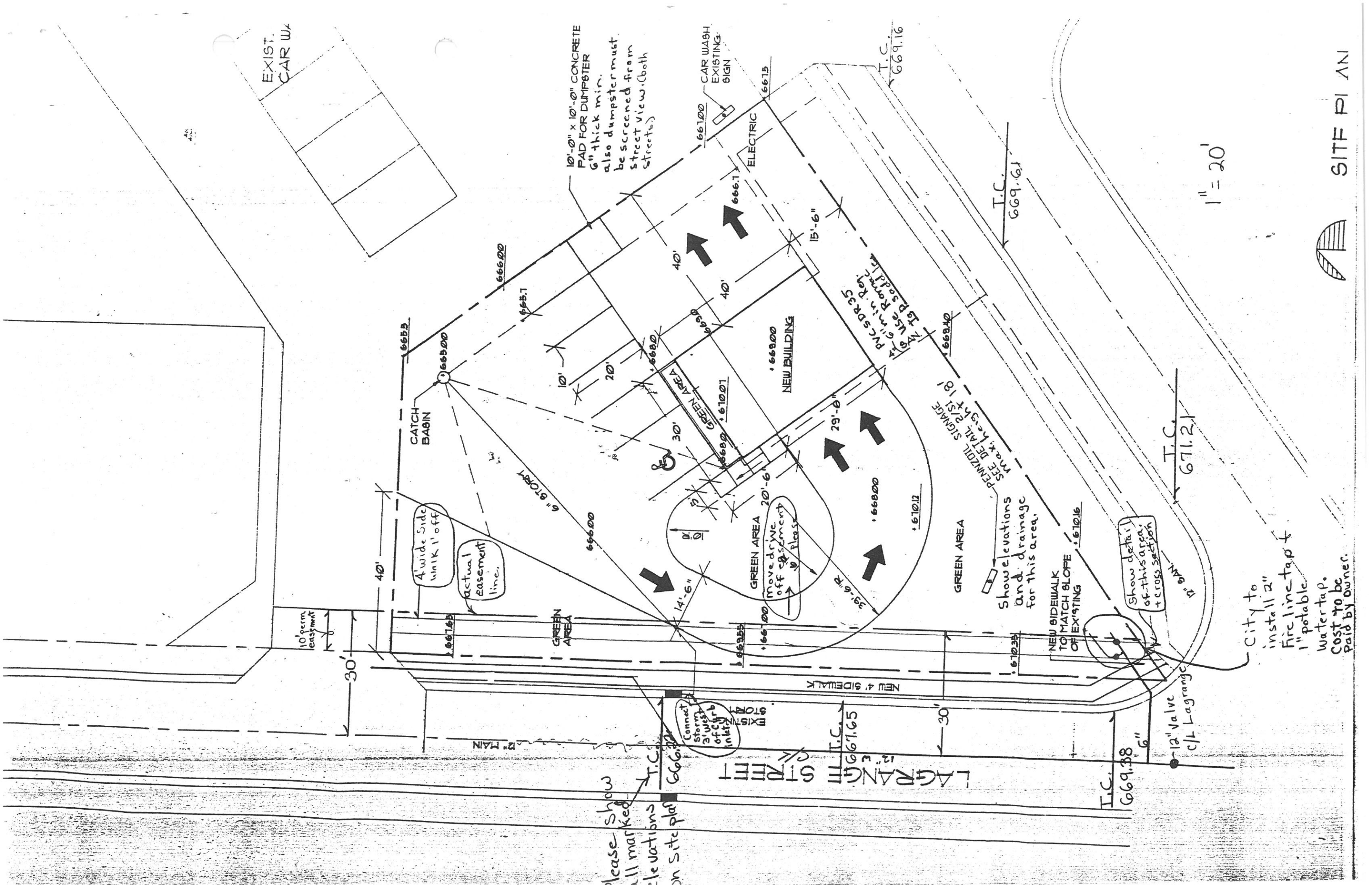

EXIST. CAR WASH

10'-0" x 10'-0" CONCRETE PAD FOR DUMPSTER 6" thick min. also dumpster must be screened from street view. (both streets.)

CAR WASH EXISTING SIGN

ELECTRIC

CATCH BASIN

NEW BUILDING

Use Form
Tg p. 5 add'l r

4' wide Side Walk 1' off

Actual Easement line.

6" STORM

GREEN AREA
MOVED TO
off easement
+ please

PENNDL SIGNAGE
SEE DETAIL 2/5/18
Max. height 18'

Show elevations and drainage for this area.

NEW SIDEWALK TO MATCH SLOPE OF EX'G

Show detail of this area, + cross section

City to install 2" Fire line tap + 1" potable water tap. Cost to be paid by owner.

Please show all marked elevations in site plan

LAGRANGE STREET

T.C. 669.38

12" Valve C/L Lagrange

1" = 20'



SITE PLAN